

Series 1600, Mechanically coupled cylinders Ø16

General

Mechanically coupled cylinder based on the stainless steel strip sealing technology widely used and tested on bigger bore sizes.

Available versions: sliding shoe as standard ("MH").

This system ensures high resistance and long life as the carriage which supports the weight is not tied to the piston and therefore the piston only transfers the movement without bearing any force.

Air connections: M5 threaded connections.

All air connections on one end cap version available. (side-back-bottom side)

Mountings:

- Foot brackets and intermediate supports if needed (depending on the stroke)
- Swivel bracket
- Directly in position via the slot on the end caps- in this conditions the air supply can come directly from the mounting plate.

Magnetic sensors: sensors series (1590.... , LRS.... and LHS....) can be used directly in the 2 slots on the barrel.

Construction characteristics

End cap	Anodised aluminium
Barrel	Anodised aluminium
Bands	Stainless steel
External carriage	Anodised aluminium
Sliding bushes	Special technopolymer
Piston	Acetal resin
Cushion bearings	Aluminium
Piston seals	Special NBR
Other seals	NBR

Technical characteristics

Fluid	Filtered air. No lubrication needed, if applied it shall be continuous.
Working pressure	1,5 - 8 bar
Working temperature	-5°C - +70°C
Max. speed	1 m/s (normal working conditions)
Max. stroke	2,5 meters
Cushioning length	18 mm

Please follow the suggestions below to ensure a long life for these cylinders:

- use clean and lubricated air
- Please adequately evaluate the load involved and its direction, especially in respect to the moving carriage (also see tables for loads and admitted moments).
- avoid high speeds together with long strokes and heavy loads: this would produce kinetic energy which the cylinder cannot absorb, especially if used as a limit stop (in this case use mechanical stop device)
- evaluate the environmental characteristics of cylinder used (high temperature, hard atmosphere, dust, humidity etc.)

Please note: air must be dried for applications with lower temperature.

Use hydraulic oils H class (ISO VG32) for correct continued lubrication.

Our Technical Department will be glad to help.

For applications where a low smooth uniform operations speed is required, you must specify this on your purchase order so that we can use the proper special grease.

Use and maintenance

This type of cylinder, due to its characteristics, has to be used within certain criteria. Correct use will give long and troublefree operation. Filtered and lubricated compressed air reduce seal wear. Verify that the load will not produce unforeseen stresses. Never combine high speed with heavy load. Always support the long stroke cylinder with intermediate brackets and never exceed the specified working conditions.

If maintenance is required, follow the instructions supplied with the repair kit.

▶ Operating end stroke decelerator diagram

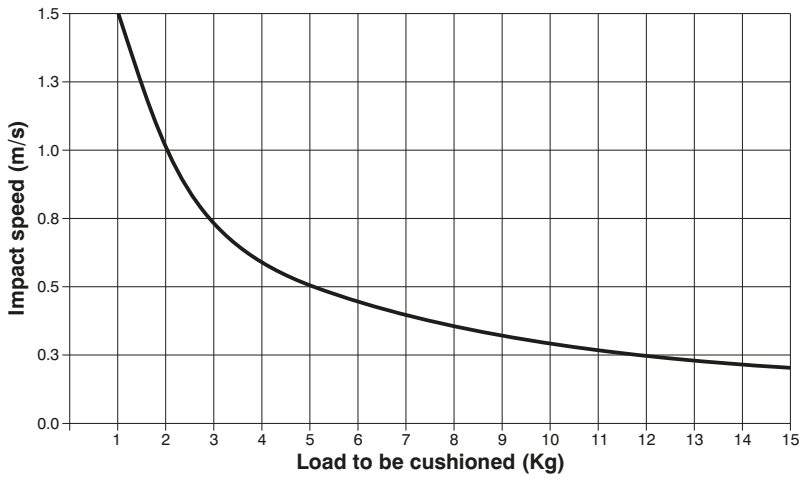

In case of extreme applications close to the maximum allowed values in the graph it is strongly recommended to add external damping systems.

▶ Suggested loads and moments

K1	K2	K	M	Ms	Mv
200	250	100	10	2	3
(N)			(Nm)		

Maximum Load and moments allowed
in static or dynamic conditions
(max. speed 0,2 m/s)

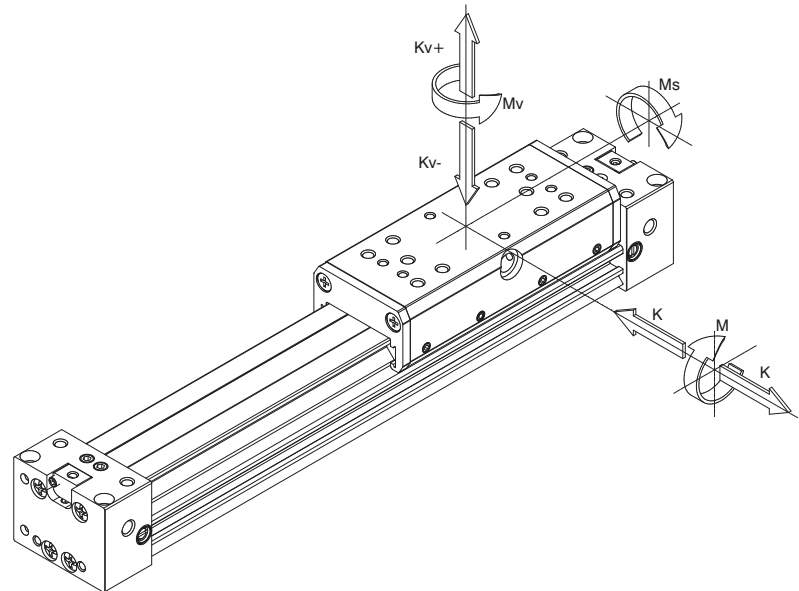

▶ Magnetic sensors

Ordering code
1590...
LRS...
LHS...

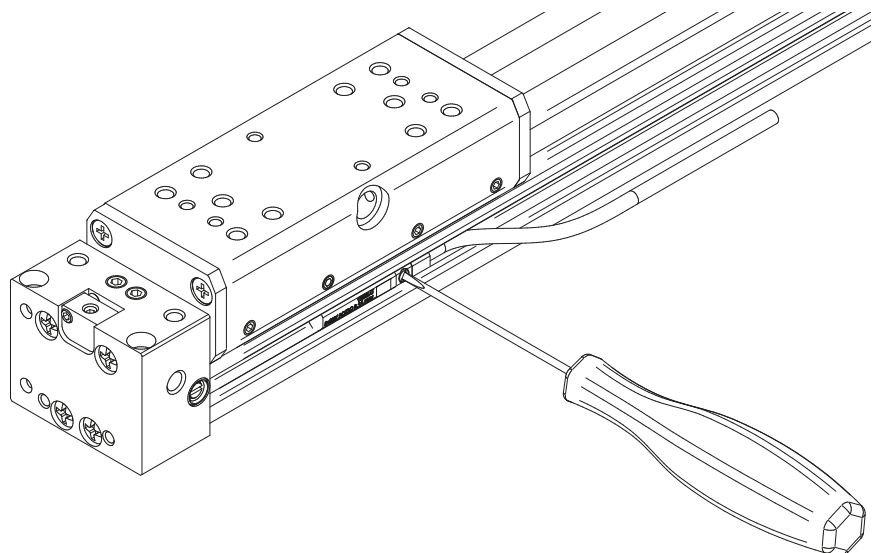

The two side slots allow the direct use of 1590...LRS... and LHS... sensors mounted from the top and positioned via the built in screw.

Mounting foot brackets

Ordering code

1600.16.01F
(1 piece)

The kit comprises:
n°1 foot (plated zinc steel)
n°2 screws (plated zinc steel)

Attention: based on the stroke evaluate the need to use also side mounted supports. (see below)

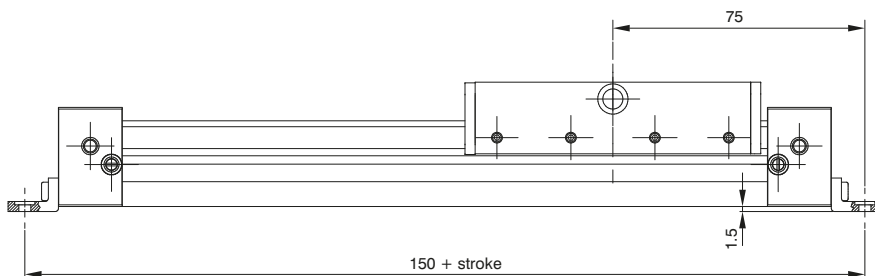
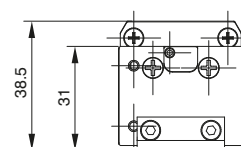
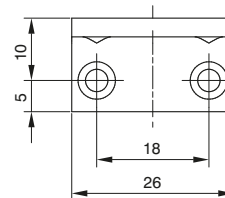
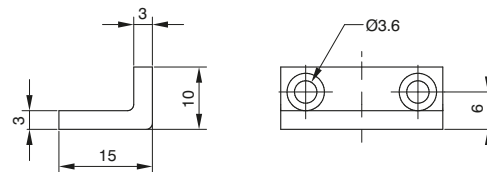
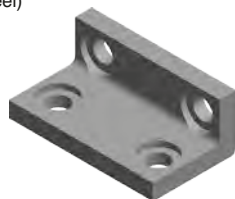

Intermediate support

Ordering code

1600.16.02F
(1 piece)

The kit comprises:
n°1 support (aluminium)
n°2 screws (plated zinc steel)

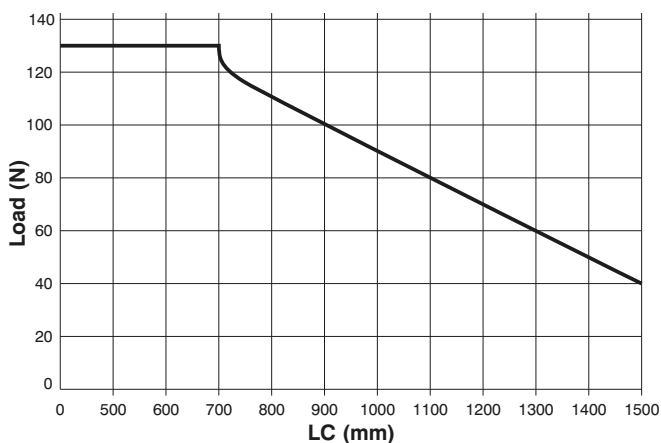
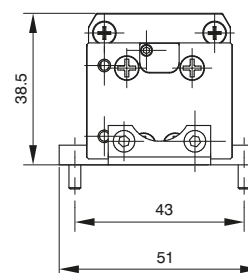
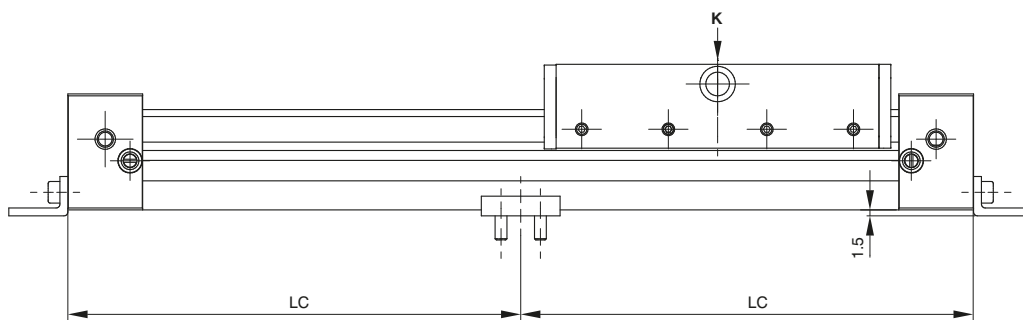
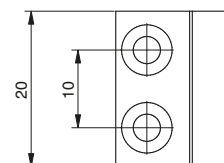
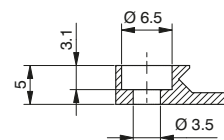
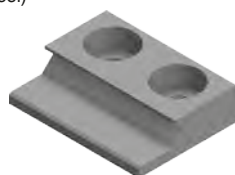

The graph shows the LC limit in conjunction with the applied load K beyond which it is necessary to mount an intermediate side support in order to prevent the barrel from bending.

Oscillating hinge

Ordering code
1600.16.03F (1 piece)

The kit comprises:
n°2 pins (plated zinc steel)
n°2 grub screw (steel)
n°1 oscillating hinge (plated zinc steel)

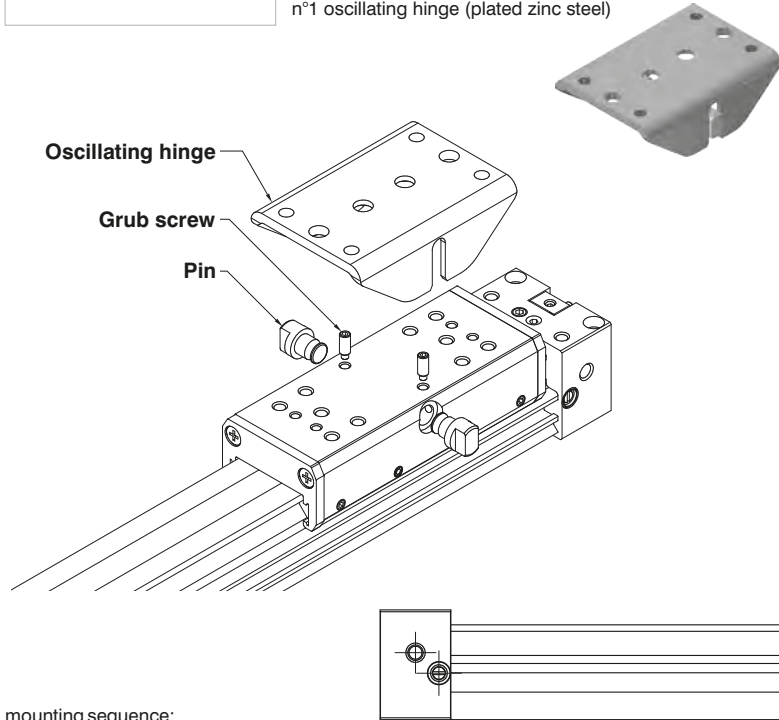
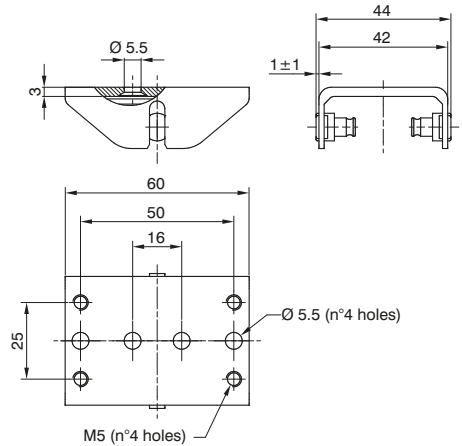

mounting sequence:
- mount the pin into the dedicated housing
- tighten the blocking grub screws in the dedicated housing

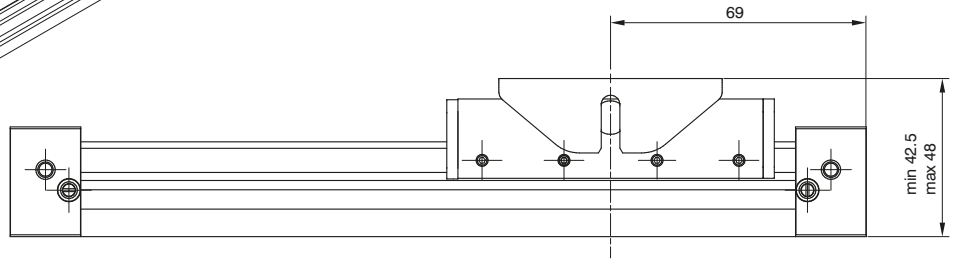

Direct mounting without brackets

Ordering code
1600.16.04F (1 piece)

The kit comprises:
n°4 screws M3x35 (plated zinc steel)
n°2 O-Rings (NBR)

Direct mounting without brackets

Thanks to the mounting holes with counter bores on the end caps it is possible to mount the cylinder directly onto the mounting surface. Having the end caps and barrel flush and in contact with the mounting plate it is not necessary to use any intermediate mounting brackets even in case of long strokes. It is also possible to supply air to the cylinder directly through the mounting plate through the two air connection on the bottom side of the end cap (06.MH and 07.MH) which are machined with counterbores.

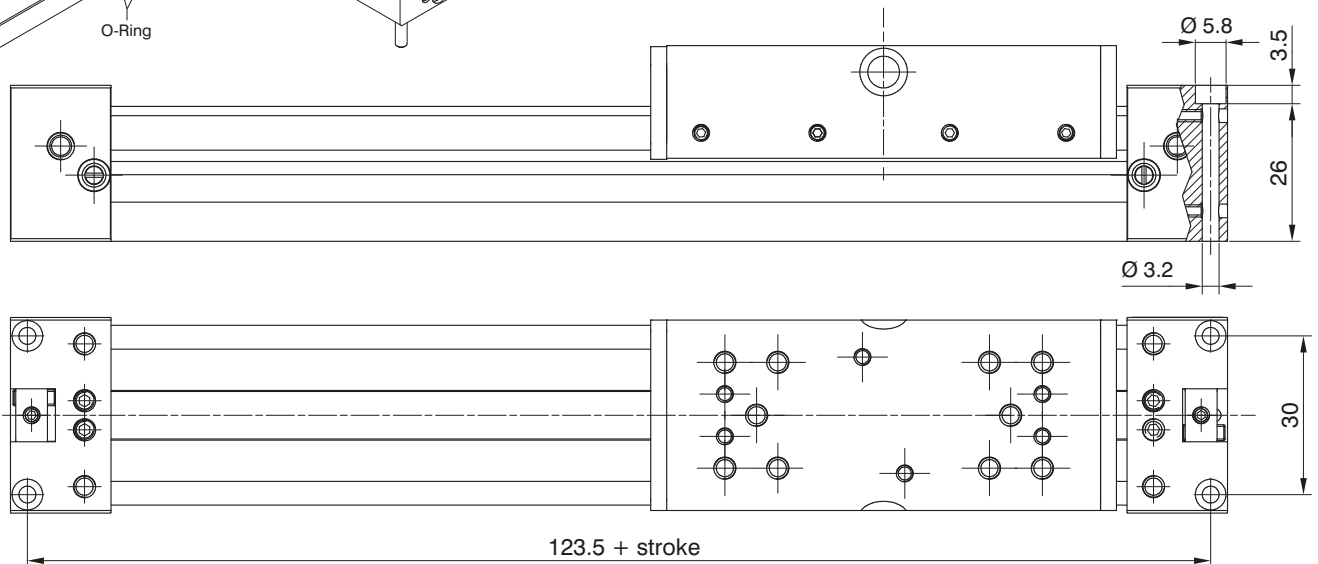
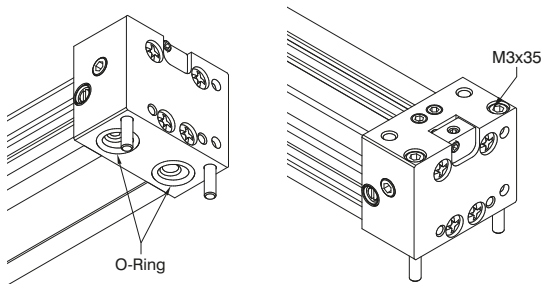

1600 Series, Cable driven cylinders

General

The cable driven cylinders work in a linear translation systems, they are very compact and can be used where a normal cylinder with a rigid rod is too cumbersome. The main characteristic of the cable cylinders is the absence of the rod which, in coming out of the end plate at the end of the stroke, doubles the total overall dimension of the cylinder. In the case of the cable cylinder, the rod is replaced by a metal rilsan-coated cable. It is connected to the piston and coming at the maximum point of stroke never exceeds the overall dimensions of the cylinder.

The cable is connected to the bracket with clamps which serve also to regulate the tension. Because of the construction characteristics of this type of cylinder it must be used with much care. The cable is capable of supporting large stress due to heavy load and high speed. Unfortunately, we cannot give definitive limits of use if not in presence of masses of a few kilograms to be translated (7 - 10 for 16 and 20 - 25 for Ø 25) with speed inversely proportional to the entity of the same load (max 0,5 m/sec). This is done in a way that the load always has a mechanical stop at the end of the stroke. The magnetic piston version lengthens the overall dimensions by 50 mm; the 1200 series microcylinder sensors are used along with the clips of that series.

Construction characteristics

End caps	anodised black aluminium	Piston seals	NBR 80 Shore (at lip)
Barrel	anodised aluminium	Cable seal	PUR
Piston	aluminium	Bracket	steel
Cable	steel	Cable clamps	brass
Cable covering	Rilsan	Pulleys	aluminium with ball bearing

Technical characteristics

Filtered air. Max. pressure: 6 bar Min. and max. temperature: -5°C - +70°C Max speed: 0.5 m/sec.
No lubrication needed, if applied it shall be continuous. **"Attention: Dry air must be used for application below 0°C"**

	A	B	C	D
Standard	111	132	86	124
Magnetic	161	182	136	174



Ordering code
1601.Ø.stroke
1601.Ø.stroke.M
Version with magnetic piston

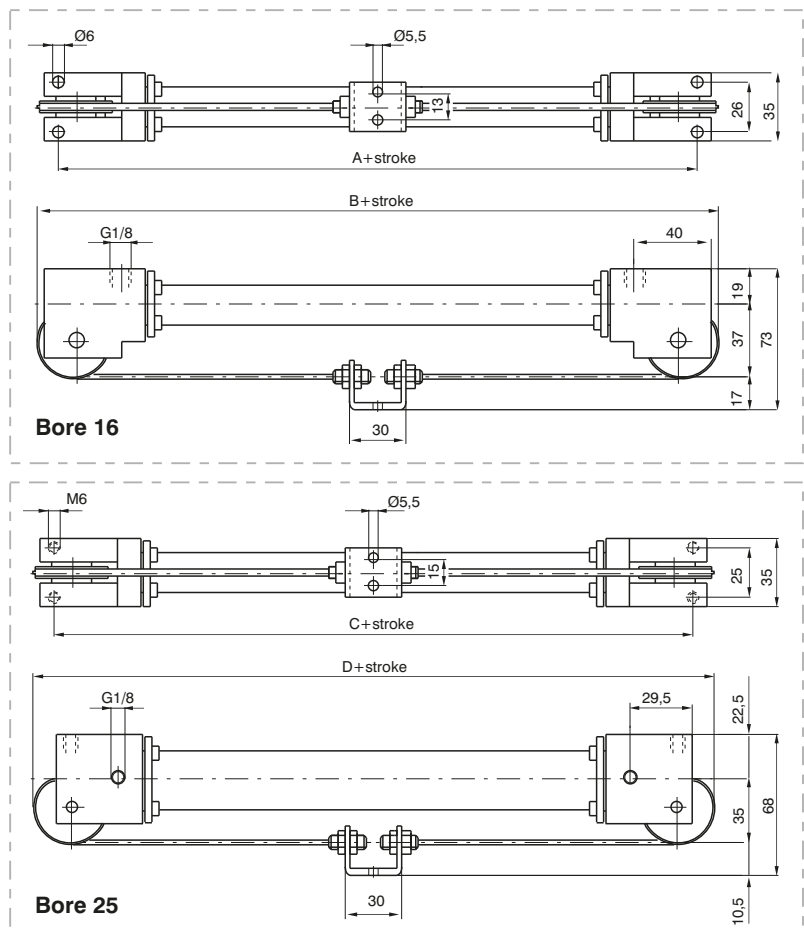

Maintenance

The cable is obviously the part most subject to breakage. The cylinder can be disassembled for replacement of the cable which is supplied already complete with threaded bushings to be screwed on to the piston. Once the wear of the barrel and seals has been checked, the cylinders can be reassembled by screwing on the end plates. Next, the ends of the cable are attached to the bracket by way of clamps and the tension regulated. The tension is correct when the cable is not cambered.

3 PNEUMATIC ACTUATION



Series 1330-1331-1332-1333, rotary actuators

Construction characteristics

End cap	UNI 5079 aluminium alloy casting
Central body	oxidised aluminium
Pinion	18 NiCrMo4 cemented and tempered
Rack	C43
Barrel	anodised aluminium Ra=0.3-0.5
Sliding shoe	acetal resin
Cushion bushings	hardened aluminium
Piston	vulcanized rubber block on steel core with incorporated permanent magnet or without magnet plus rear spacer for non magnetic version
Seals	NBR 80 shore rubber
Cushion adjustment screw	nickel plated steel
Rotating angle adjustment assy	nickel plated brass

Operational characteristics

Fluid	Filtered air. No lubrication needed, if applied it shall be continuous.
Max. pressure	10 bar
Working temperature	-5°C - +70°C
Standard rotation	90° - 180° - 270° - 360°(+1°)
Rotating angle adjustment assy	±10° (±5° start position, ±5° end position)

Please follow the suggestions below to ensure a long life for these cylinders:

- use clean and lubricated air
- correct alignment during assembly with regard to the applied load so as to avoid radial components or bending the rod.
- avoid high speeds together with long strokes and heavy loads: this would produce kinetic energy which the cylinder cannot absorb, especially if used as a limit stop (in this case use mechanical stop device)
- evaluate the environmental characteristics of cylinder used (high temperature, hard atmosphere, dust, humidity etc.)

Please note: air must be dried for applications with lower temperature.

Use hydraulic oils H class (ISO VG32) for correct continued lubrication.

Our Technical Department will be glad to help.

Bore	32	40	50	63	80	100
Torque moments Nm/bar	0,9	1,7	2,9	5,55	13,2	23,8
Axis load max. kg.	8	10	10	12	18	22
Cushioning angle	60°	60°	50°	50°	40°	40°



Series 1605, Mechanically coupled

General

The purpose of producing a rodless cylinder is to provide a space saving option over conventional cylinders. On a traditional rod type cylinder, the total space occupied with rod out is more than double the length of the cylinder, while with rodless cylinder it is little more than its stroke. Profiled tube allows mounting of sensors 1500._, RS._, HS._ and 1580._, MRS._, MHS._ on the two sides of carriage, by means of suitable brackets. Standard accessories include foot mounting brackets for installation on cylinder and caps, intermediate mounting brackets to give support to long stroke cylinders under load (over one metre), an oscillating coupling device for installation between the mounting plate and the load and on request, a very precise external movement device.

Construction characteristics

End covers	anodised aluminium
Barrel	anodised aluminium
Bands	tempered stainless steel
Mounting place	anodised aluminium
Piston	acetal resin
Guide blocks	acetal resin
Cushion bearings	aluminium
Piston seals	special 80 shore nitril mixture, wear resistant
Other seals	NBR oil-resistant rubber

Caratteristiche di funzionamento

Fluid	Filtered air. No lubrication needed, if applied it shall be continuous.
Pressure	0.5 - 8 bar
Working temperature	-5°C - +70°C
Max. speed	1.5 m/sec. (normal working conditions)
Bores	Ø 25 - 32 - 40 - 50 - 63
Max. strokes	6 m

Please follow the suggestions below to ensure a long life for these cylinders:

- use clean and lubricated air
- Please adequately evaluate the load involved and its direction, especially in respect to the moving carriage (also see tables for loads and admitted moments).
- avoid high speeds together with long strokes and heavy loads: this would produce kinetic energy which the cylinder cannot absorb, especially if used as a limit stop (in this case use mechanical stop device)
- evaluate the environmental characteristics of cylinder used (high temperature, hard atmosphere, dust, humidity etc.)

Please note: air must be dried for applications with lower temperature.

Use hydraulic oils H class (ISO Vg32) for correct continued lubrication.

Our Technical Department will be glad to help.

For applications where a low smooth uniform operations speed is required, you must specify this on your purchase order so that we can use the proper special grease.

Use and maintenance

This type of cylinder, due to its characteristics, has to be used within certain criteria. Correct use will give long and troublefree operation. Filtered and lubricated compressed air reduce seal wear. Verify that the load will not produce unforeseen stresses. Never combine high speed with heavy load. Always support the long stroke cylinder with intermediate brackets and never exceed the specified working conditions.

If maintenance is required, follow the instructions supplied with the repair kit.

► **Basic version**

Ordering code
1605.Ø.stroke.01.M
(Max. stroke 6 mt.)

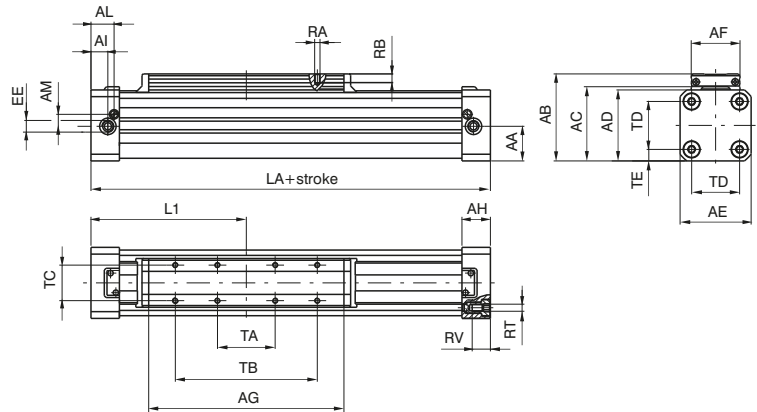

► **Left head**

Ordering code
1605.Ø.stroke.02.M
(Max. stroke 6 mt.)

Possibility of a single feed cylinder head

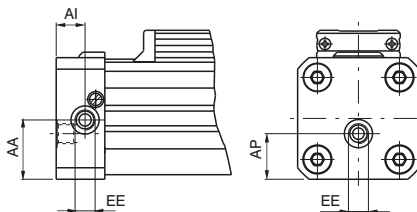

► **Right head**

Ordering code
1605.Ø.stroke.03.M
(Max. stroke 6 mt.)

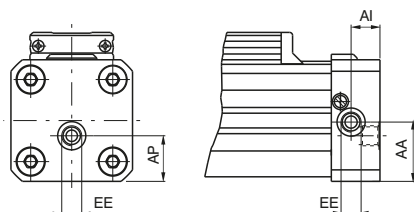

Bore	25	32	40	50	63	
AA	19,5	25,5	31	39	46,5	
AB	56	70	80	98	113,5	
AC	48,5	60	70	85	100	
AD	44	55	65	80	95	
AE	40	55	65	80	95	
AF	30	40	40	55	55	
AG	117	146	186	220	255	
AH	23	27	30	32	36	
AI	12,5	14,5	17,5	19	23	
AL	19	22,5	24,5	26	30	
AM	7,5	10,5	11,5	13,5	16	
AP	13	15,2	23	30	35,5	
EE	G1/8"	G1/4"	G1/4"	G1/4"	G3/8"	
L1	100	125	150	175	215	
LA	200	250	300	350	430	
RA	M4	M5	M5	M6	M6	
RB	7,5	9,5	9,5	11,5	11,5	
RT	M5	M6	M6	M8	M8	
RV	13,5	16,5	16,5	20,5	20,5	
TA	30	40	40	65	65	
TB	80	110	110	160	160	
TC	23	30	30	40	40	
TD	27	36	47	54	68	
TE	6,5	9,5	9	13	13,5	
Weight	stroke 0	900	1650	2650	4330	8010
g	every 100mm	225	340	490	725	1070
STROKE TOLERANCE: + 2 mm.						

Basic version cylinder

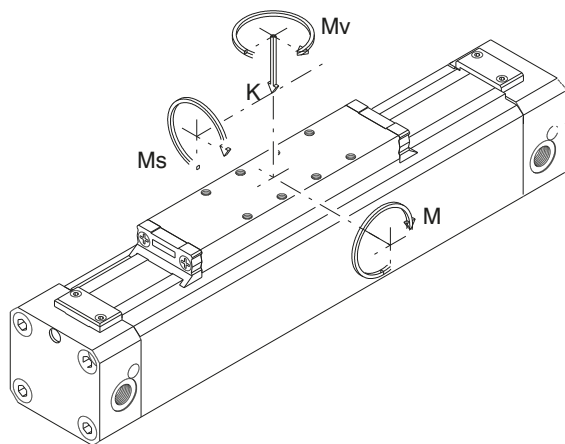

Operating end stroke decelerator diagram

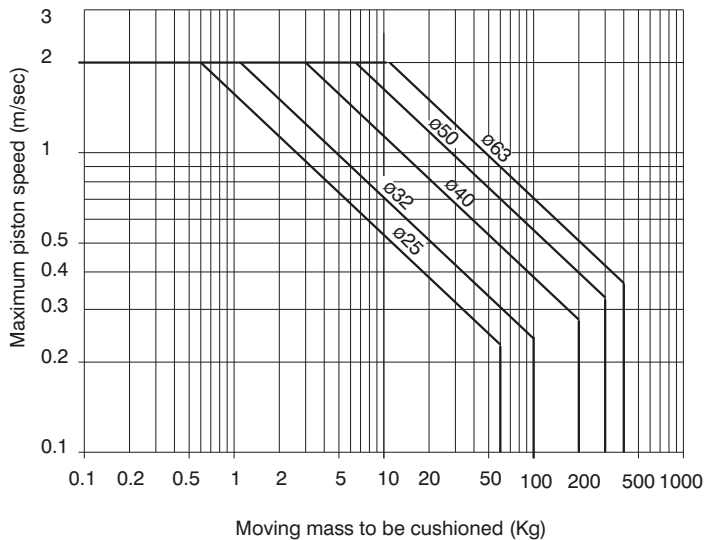

3 PNEUMATIC ACTUATION

Recommended loads and moments in static conditions

CYLINDER BORE	DECELERATING STROKE (mm)	MAX. RECOMMENDED LOAD K (N)	MAX. RECOMMENDED BENDING MOMENT M (Nm)	MAX. RECOMMENDED CROSS MOMENT Ms (Nm)	MAX. RECOMMENDED TWISTING MOMENT Mv (Nm)
25	20	300	15	0.8	3
32	25	450	30	2.5	5
40	31	750	60	4.5	8
50	38	1200	115	7.5	15
63	49	1600	150	8.5	24

Attention: use guided carriage for heavier loads or precise linear movements (MG or MH versions).

All reported data are referred to carriage plane and indicates MAX - values in static conditions. These values should not be exceeded either in dynamic conditions (best speed <1m/sec). Should the cylinder be utilised at its maximum performances, ensure the proper additional absorbers are used.

Calculation of permissible load (Kd) in dynamic conditions $K_d = K \cdot C_v$

Coefficient of velocity diagram

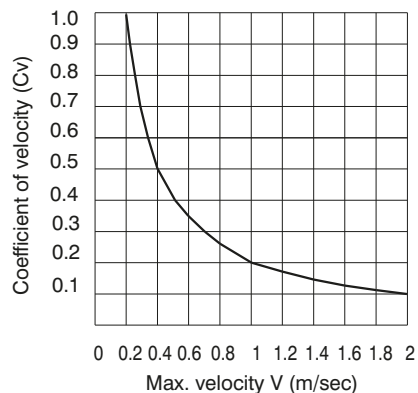

Loads under combined stressing conditions

It is important to take into consideration the following formula when there are a combination of forces with torque:

$$\left[\left(2 \times \frac{M_s}{M_{s \max}} \right) + \left(1.5 \times \frac{M_v}{M_v \max} \right) + \frac{M}{M \max} + \frac{K}{K \max} \right] \times \frac{100}{C_v} \leq 100$$

► **Cylinder with linear control unit (Ø 25, Ø32, Ø40 and Ø50)**

Ordering code
1605.Ø.stroke.01.MG
(Max. stroke 3mt.)



Cylinders Ø 25

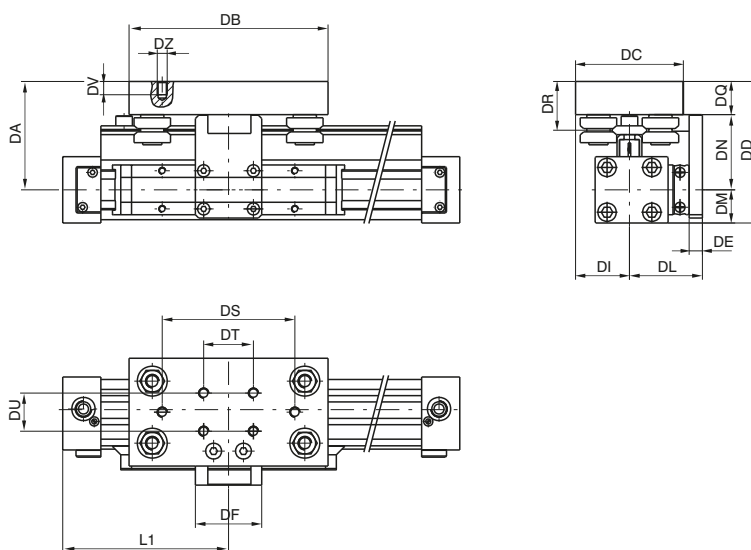

Cylinders Ø 32, Ø 40, Ø 50

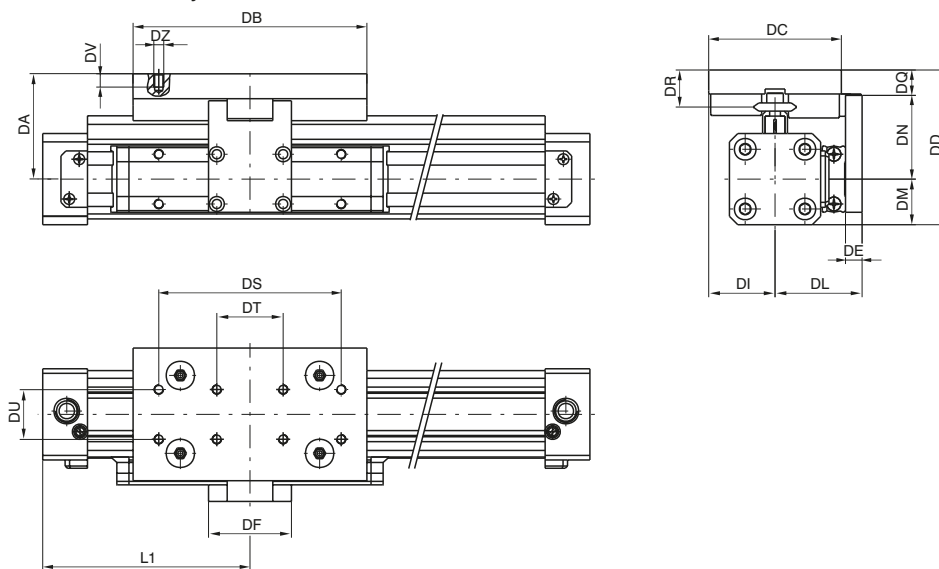

Bore	DA	DB	DC	DD	DE	DF	DI	DL	DM	DN	DQ	DR	DS	DT	DU	DV	DZ	L1	Weight guide	every 100mm
25	65	120	65	85	8	40	32,5	44	20	45,5	19,5	29	80	30	23	8	M6	100	g 850	g 90
32	63	141	80	90,5	10	50	40	52,5	27,5	48,5	14,5	21,5	110	40	30	8	M5	125	g 950	g 90
40	68,5	141	80	101	10	50	40	57,5	32,5	54	14,5	21,5	110	40	30	8	M5	150	g 950	g 90
50	76	141	80	116	12	80	40	70	40	61,5	14,5	21,5	110	40	30	8	M5	175	g 950	g 90

For cylinder weight refer to base version

Construction characteristics of linear control unit

Rod	carbon steel with hardness higher than 55-60 HRC
Bearing with shaft	shielded bearing with shaped ring
Carriage plate	anodised aluminium
Cover	acetal resin

Cylinders with linear control unit Ø32, Ø40 and Ø50

Max. suggested loads and moments

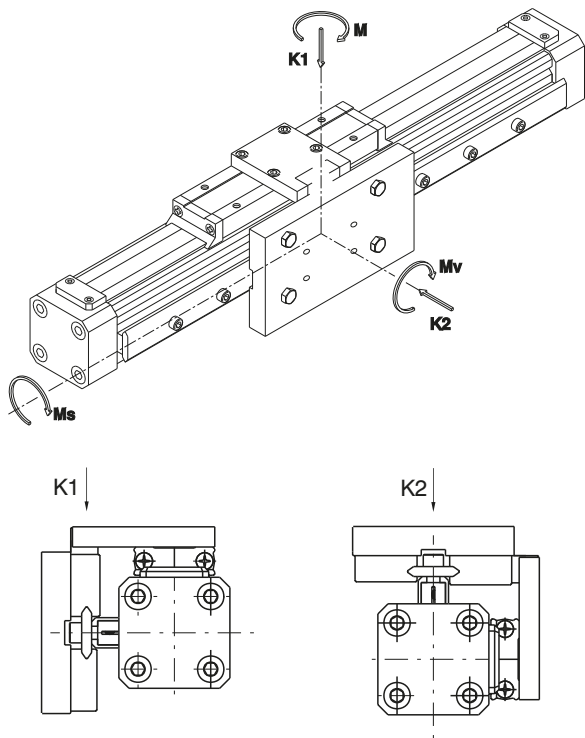

K1 (N)	K2 (N)	M (Nm)	Ms (Nm)	Mv (Nm)
960	960	40	12	40

Max. load (K1 o K2) depending on the distance LC between the supports

K1 K2

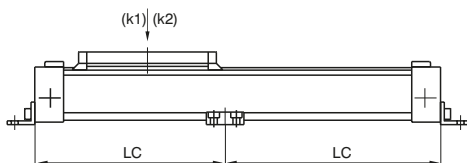
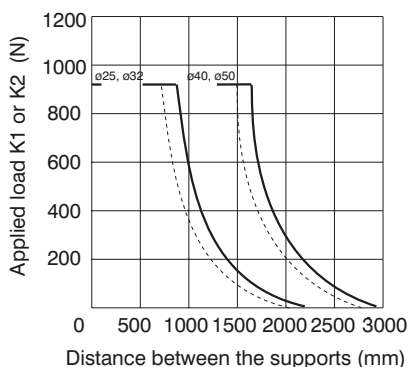

Real load (CE) under combined stressing conditions

It is important to take into consideration the following formula when there are a combination of forces with torque :

$$CE = [K1 + K2 + (24 \times M) + (80 \times Ms) + (24 \times Mv)] \leq 960$$

Nomograph load / life

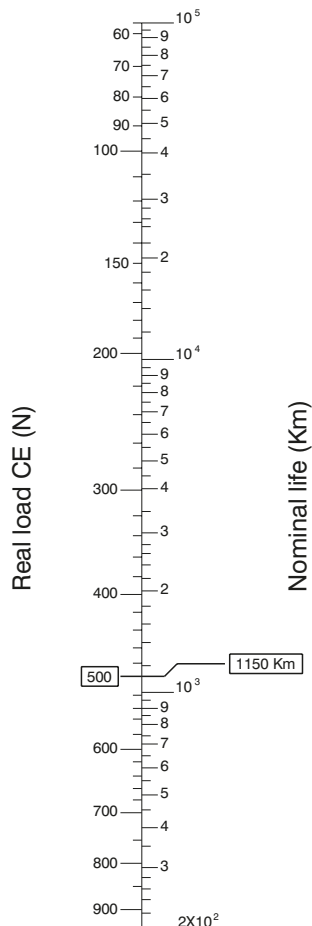

All data refers to a linear control unit properly lubricated with linear speed < di 1.5 m/s

Example to compute the life

Compute the linear control unit life with a load of 100 N applied 50 mm off its axle.

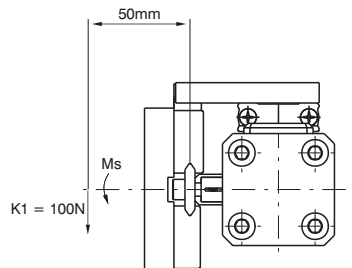

$$Ms = 0,05 \times 100 = 5 \text{ Nm}$$

$$K1 = 100 \text{ N}$$

How to compute the real load using the formula:

$$CE = [K1 + K2 + (24 \times M) + (80 \times Ms) + (24 \times Mv)]$$

$$CE = [100 + 0 + (24 \times 0) + (80 \times 5) + (24 \times 0)] = 500 \text{ N}$$

After having verified that the CE is lower than 960 N we realise that the life is 1150 Km from the nomograph.

► **Cylinder with sliding shoes guide** (Ø 25, Ø 32, Ø 40, Ø 50 and Ø 63)

Ordering code
1605.Ø.stroke.01.MH

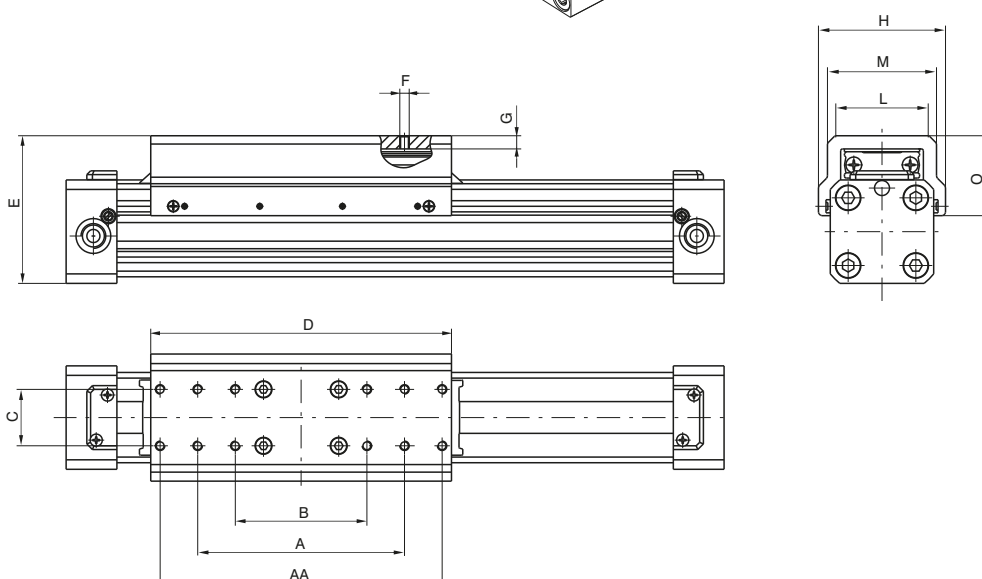
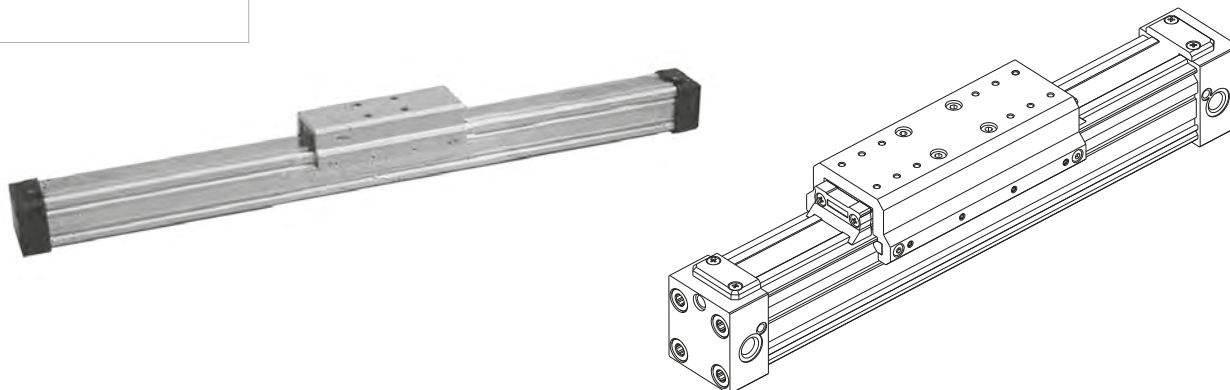

Bore	AA	A	B	C	D	E	F	G	H	L	M	O	Weight g
Ø25	/	80	55	23	130	64 ^{±1}	M4	6,5	57	36	42	32	g 235
Ø32	/	110	70	30	160	78,5 ^{±1}	M5	7	68	50	58	42,5	g 445
Ø40	/	110	70	30	202	88,5 ^{±1}	M5	7	77	52	60	45,5	g 595
Ø50	210	160	110	40	235	114,5 ^{±1}	M6	14	100	71	83	61,5	g 1453
Ø63	210	160	110	40	270	130 ^{±1}	M6	14	116	76	90	65,5	g 1810

For cylinders weight refer to base version

► **Complete sliding shoes guide**

Ordering code
1600.Ø.05F



Construction characteristics of guide

Sliding shoes guide	reinforced carbon fibre nylon
Mounting plate	extruded anodised aluminium

Cylinder with sliding shoes guide $\varnothing 25$, $\varnothing 32$, $\varnothing 40$, $\varnothing 50$ and $\varnothing 63$

Max. suggested loads and moments

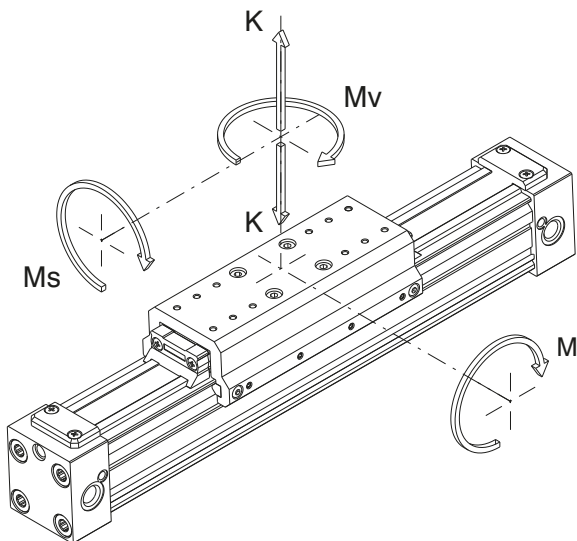

Recommended loads and moments in static conditions

CYLINDER BORE	MAX RECOMMENDED LOAD K (N)	MAX RECOMMENDED BENDING MOMENT M (Nm)	MAX RECOMMENDED CROSS MOMENT Ms (Nm)	MAX RECOMMENDED CROSS MOMENT Ms (Nm)
$\varnothing 25$	300	20	1	4
$\varnothing 32$	450	35	3	6
$\varnothing 40$	750	70	5	9
$\varnothing 50$	1200	120	8	16
$\varnothing 63$	1600	155	9	25